

DATA SHEET

TDA4800

Vertical deflection circuit for monitor applications

Product specification
Supersedes data of February 1992
File under Integrated Circuits, IC02

1997 Mar 27

Vertical deflection circuit for monitor applications

TDA4800

FEATURES

- Fully integrated, few external components
- RC oscillator with wide sync range of 1 : 3 (e.g. 50 to 150 Hz)
- Synchronization by positive or negative going sync pulse
- Blanking pulse duration is determined externally
- Dual frequency criterion for automatic amplitude switch-over (e.g. 50 to 60 Hz)
- Guard circuit for screen protection
- Sawtooth generator with buffer stage supplied by external voltage
- Preamplifier
- Power output stage with thermal and SOAR protection
- Flyback generator
- Internal voltage stabilizer.

GENERAL DESCRIPTION

The TDA4800 is an integrated circuit for vertical deflection primarily in monitors (and TV receivers). The complete circuit consists of 11 main functional blocks as shown in Fig.1.

QUICK REFERENCE DATA

SYMBOL	PARAMETER	CONDITIONS	MIN.	TYP.	MAX.	UNIT
V_{P1}	supply voltage (pin 6)		10	–	30	V
V_{P2}	supply voltage (pin 10)		10	–	45	V
I_P	supply current (pins 6 and 10)	note 1	–	215	–	mA
$I_{7(p-p)}$	output current (peak-to-peak value)		–	–	2.6	A
f_{sync}	picture frequency	notes 1 and 2	–	–	135	Hz
V_3	positive sync input pulse		1.0	–	6.0	V
V_3	negative sync input pulse		–0.5	–	–0.7	V
T_{amb}	operating ambient temperature	note 3	–20	–	+70	°C

Notes

1. Measured in Fig.4.
2. $f_o = 45 \text{ Hz}$ ($f_{sync(max)} = 3f_o$).
3. $P_{tot} = 3.6 \text{ W}$ for $R_{th(j-a)} = 20 \text{ K/W}$.

ORDERING INFORMATION

TYPE NUMBER	PACKAGE		
	NAME	DESCRIPTION	VERSION
TDA4800	DBS13P	plastic DIL-bent-SIL power package; 13 leads (lead length 12 mm)	SOT141-6

Vertical deflection circuit for monitor applications

TDA4800

BLOCK DIAGRAM

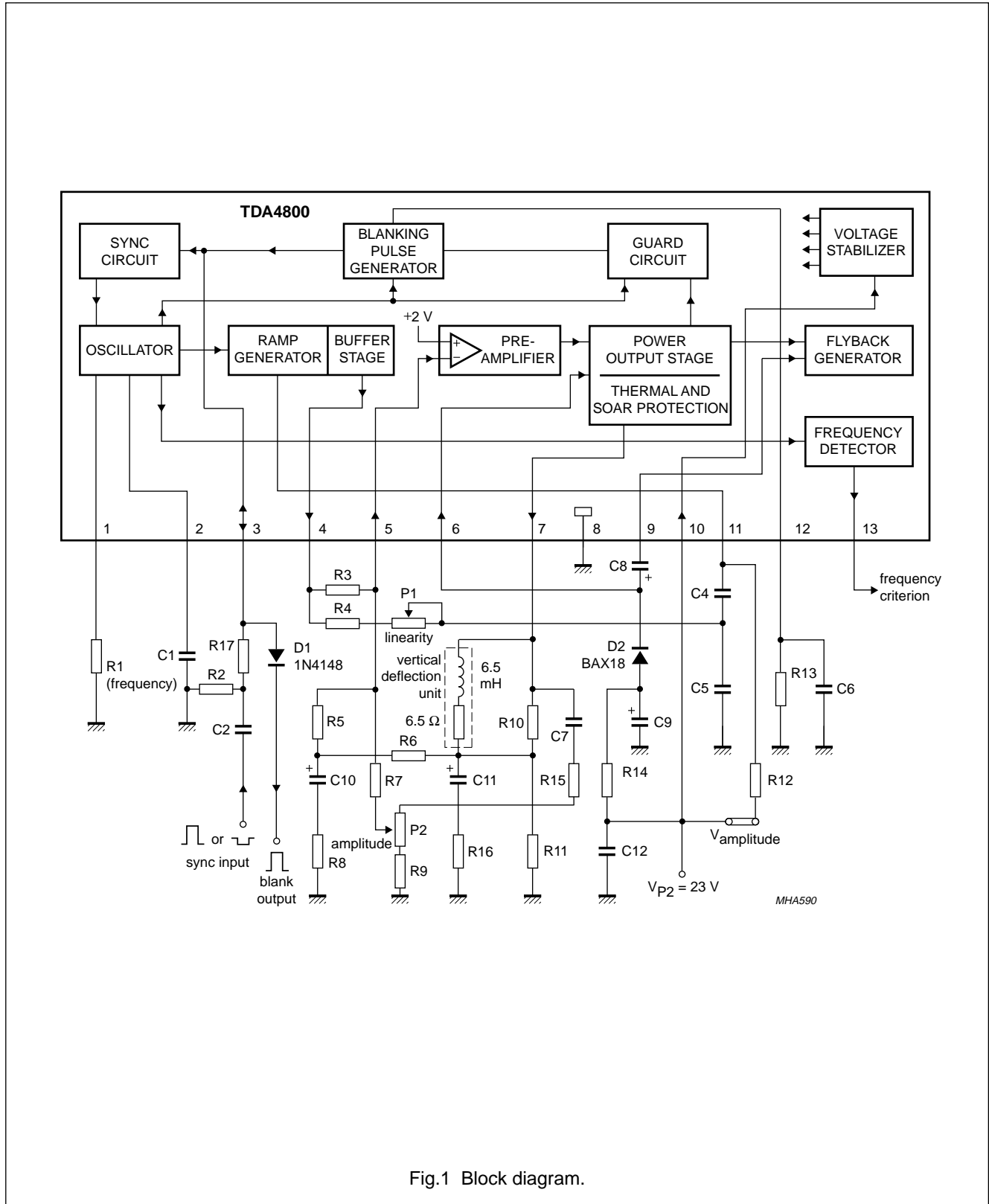

Fig.1 Block diagram.

Vertical deflection circuit for monitor applications

TDA4800

PINNING

SYMBOL	PIN	DESCRIPTION
OSC _R	1	oscillator resistor
OSC _C	2	oscillator capacitor
SYB _O	3	sync input; blanking pulse output
S _{OUT}	4	sawtooth output
PRE _I	5	preamplifier input
V _{P1}	6	supply voltage 1
OUTP	7	deflection output
GND	8	ground
C _{FLY}	9	pin for the flyback generator capacitor
V _{P2}	10	supply voltage 2
S _{GEN}	11	sawtooth generator
BP _{DU}	12	blanking pulse duration
FRQ _C	13	frequency criterion

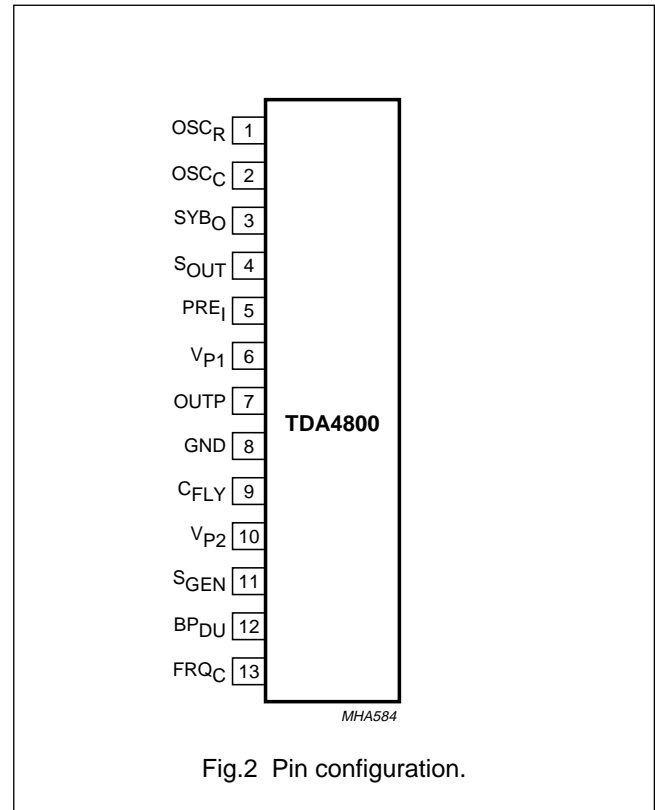

Vertical deflection circuit for monitor applications

TDA4800

FUNCTIONAL DESCRIPTION

The complete circuit consists of the following functional blocks as shown in Fig.1:

1. Oscillator
2. Synchronization circuit
3. Blanking pulse generator
4. Frequency detector and storage
5. Ramp generator
6. Buffer stage
7. Preampifier
8. Power output stage
9. Flyback generator
10. Guard circuit
11. Voltage stabilizer.

Oscillator (pins 1 and 2)

The oscillator is an RC-oscillator with a threshold value switch, which ensures very good frequency stability.

The upper and lower threshold voltages are defined by an internal voltage divider.

An external capacitor C1 at pin 2 is charged by a constant current source. When the scan voltage of C1 reaches the upper threshold voltage, oscillator flyback starts. Capacitor C1 discharges via an internal resistor and transistor until the lower threshold is reached.

The constant charge current and free-running frequency f_o are adjusted by an external resistor R1 at pin 1:

$$f_o = \frac{1}{K \times R1 \times C1} \text{ with } K = 0.68.$$

Synchronization circuit (pin 3)

A positive- or negative-going pulse fed to pin 3 synchronizes the oscillator by lowering the upper threshold voltage. The synchronizing range is f_o to $3f_o$. For example: $f_o = 50 \text{ Hz} \rightarrow f_{\text{sync(max)}} = 150 \text{ Hz}$.

Blanking pulse generator (pin 3)

Also at pin 3 a blanking pulse is available. Diode D1 separates the synchronization pulse from the blanking pulse. During scanning, the external capacitor C6 at pin 12 is charged to an internal stabilized voltage V_{stab2} . The blanking pulse starts with the beginning of oscillator flyback; then capacitor C6 discharges via the external resistor R13 at pin 12. The blanking pulse stops when the capacitor voltage is $\frac{1}{2}V_{\text{stab2}}$.

The blanking pulse duration is determined by the values of external components R13 and C6 at pin 12:

$$t_{bl} = R13 \times C6 \times \text{Ln}2.$$

Frequency detector with storage (pin 13)

At the end of the scanning period a frequency detector detects the oscillator frequency (see "Note" below).

When this frequency is above the threshold a flip-flop is set to store this information. The output is an open collector output.

NOTE

Frequency detector change-over at pin 13 from low (= low frequency) to high (= high frequency) is determined by f_o : $f_{\text{threshold}} = 1.23 \times f_o$.

Ramp generator (pin 11)

The ramp generator consists of two external series capacitors C4 and C5, external charge resistor R12 (connected to pin 11), and an internal differential amplifier which is synchronously switched by the oscillator.

External capacitors C4 and C5 at pin 11 are charged by the charging current via the external charge resistor R12 until oscillator flyback starts. C4 and C5 are then discharged via pin 11 by an internal resistor and transistor. This generates a positive-going ramp voltage.

Buffer stage (pin 4)

The buffer stage consists of two emitter followers. The ramp voltage is fed via the buffer stage and is available at pin 4 with a low ohmic output impedance. With R4 and P1 it generates a ramp function, which, together with the feedback network of the deflection yoke, gives a high degree of linearity at the picture tube. The linearity can be adjusted by P1.

Preampifier (pin 5)

The preampifier is a differential amplifier. The non-inverting input is fixed at about 2 V by an internal voltage divider. The inverting input at pin 5 is connected to the ramp voltage via R3 and feedback network P2, R5 to R11, R15, R16, C7, C10 and C11.

Power output stage (pin 7)

The power output stage is an amplifier with a quasi-complementary class-B output. The output is connected to pin 7.

The power stage includes SOAR and thermal protection.

Vertical deflection circuit for monitor applications

TDA4800

Flyback generator (pin 9)

The flyback generator has an external capacitor C8 at pin 9. During scanning, the internal circuit switches pin 9 almost to ground; thereby C8 is charged by the supply voltage via external components R14 and D2.

During the flyback time pin 9 is switched almost to the supply voltage, so that the supply voltage for the power output stage (pin 6) is nearly doubled. This high flyback voltage ensures a very short flyback time.

Guard circuit (pin 3)

When the vertical deflection current is absent (e.g. short-circuited, or open-circuited of the yoke) the guard circuit changes the blanking pulse at pin 3 into a DC signal which blanks the beam current to protect the screen.

Also an oscillator defect (C1 short-circuited or R1 disconnected from pin 1) switches on the guard circuit.

Voltage stabilizer

The voltage stabilizer circuit provides a stable operating voltage of about 7.5 V for several internal circuits of the TDA4800.

INTERNAL CIRCUITRY

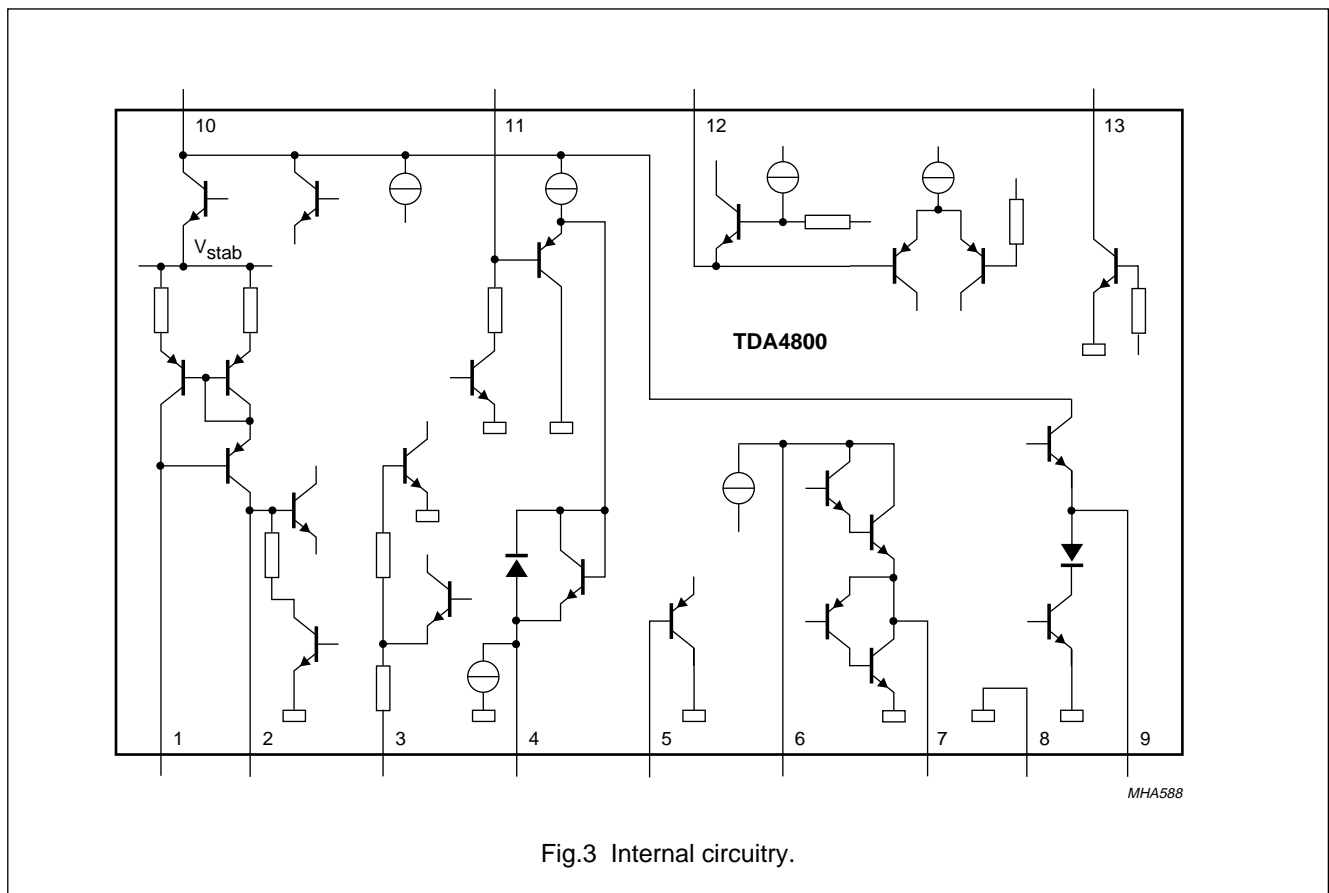

Fig.3 Internal circuitry.

Vertical deflection circuit for monitor applications

TDA4800

LIMITING VALUES

In accordance with the Absolute Maximum Rating System (IEC 134).

SYMBOL	PARAMETER	CONDITIONS	MIN.	MAX.	UNIT
V ₂	voltages		0	6	V
V ₁₁			0	24	V
V ₁₂			0	6	V
V ₁₃			0	50	V
V ₁₀	supply voltages (V _P)		0	50	V
V ₉			0	50	V
V ₇			0	60	V
V ₆			0	60	V
V ₅			0	6	V
V ₄			0	24	V
V ₃			-0.7	+6	V
I ₁			currents		0
I ₃	+3	-10			mA
I ₄	0	-5			mA
I _{6, I₇, I₈}	note 1				
I ₉	-1.5	+1.5			A
I ₁₁	-0.1	+30			mA
T _{stg}	storage temperature		-25	+150	°C
T _{amb}	operating ambient temperature	note 2	-20	+70	°C
T _j	junction temperature	note 3	-	150	°C
P _{tot}	total power dissipation	note 2	-	-	W
V _{ESD}	ESD sensitivity	note 4	-2000	+2000	V

Notes

- I₆, I₇ and I₈ are limited by SOAR protection circuit that ensures that short-circuiting between the output pin 7 and supply voltage or ground does not destroy the output stage. A short-circuit may be soldered into the printed-circuit board or may sometimes (non-periodically) occur in the applied circuit.
- The maximum value for the operating ambient temperature range and the power dissipation depends on the heatsink.
- Internally limited by thermal protection: switching temperature point at T_j = 150 ± 8 °C.
- Human body model: 1.5 kΩ, 100 pF, 5 pulses.

THERMAL CHARACTERISTICS

SYMBOL	PARAMETER	VALUE	UNIT
R _{th(j-a)}	thermal resistance from junction to ambient	20	K/W
R _{th(j-mb)}	thermal resistance from junction to mounting base	5	K/W

Vertical deflection circuit for monitor applications

TDA4800

CHARACTERISTICS

All voltages are measured to GND (ground; pin 8); $T_{amb} = 25\text{ °C}$; $V_P = 23\text{ V}$; unless otherwise specified.

SYMBOL	PARAMETER	CONDITIONS	MIN.	TYP.	MAX.	UNIT
V_{P1}	supply voltage (pin 6)		10	–	30	V
V_{P2}	supply voltage (pin 10)		10	–	45	V
I_{10}	supply current	$V_{10} = 25\text{ V}$; $V_5 = 3\text{ V}$ without load	–	12	–	mA
I_6	supply current	$V_6 = 25\text{ V}$; $V_5 = 1\text{ V}$ without load	–	20	–	mA
I_6	supply current	$V_6 = 25\text{ V}$; $V_5 = 3\text{ V}$ without load	–	5	–	mA
$V_{7(\min)}$	minimum output voltage	$I_7 = 1\text{ A}$	–	1.4	1.65	V
$V_{7(\max)}$	maximum output voltage	$I_7 = -1\text{ A}$	$V_6 - 2.3$	$V_6 - 2.0$	–	V
V_9	output voltage during flyback	$I_9 = -1\text{ A}$	–	$V_{10} - 2.2$	–	V
I_7	output current		–	–	± 1.3	A
I_9	output current		–	–	± 1.3	A
I_5	preamplifier input current		–	-0.1	–	μA
V_1	stabilized voltage		6.1	6.8	7.3	V
V_3	blanking pulse output voltage		–	5.7	–	V
R_3	blanking pulse output resistance		–	300	–	Ω
I_3	blanking pulse output current		0	–	-3	mA
t_{bl}	blanking pulse duration	$R = 100\text{ k}\Omega$; $C = 10\text{ nF}$ (pin 12)	640	680	730	μs
V_{11}	output voltage ramp generator		0.3	–	20	V
I_{11}	output current ramp generator		-2	–	15×10^3	μA
V_{13}	output voltage frequency detector	lower frequency $I_{13} = 1\text{ mA}$	–	–	1.0	V
I_{13}	leakage current frequency detector	higher frequency $V_{13} = 50\text{ V}$	–	–	1.0	μA
V_4	output voltage buffer stage		0	–	20	V
I_4	output current buffer stage		–	–	-4.0	mA
V_3	synchronizing input voltage	positive sync	1.0	–	6.0	V
V_3	synchronizing input voltage	negative sync	-0.5	–	-0.7	V
	tolerance of free running oscillator	without sync	-3.0	–	+3.0	%
$\frac{\Delta f}{f} \times \frac{1}{\Delta T_{mb}}$	oscillator temperature dependency	$T_{mb} = 20\text{ to }100\text{ °C}$	–	10^{-4}	–	K^{-1}
$\frac{\Delta f}{f} \times \frac{1}{\Delta V_P}$	oscillator voltage dependency	$V_P = 10\text{ to }30\text{ V}$	–	4×10^{-4}	–	K^{-1}
$\frac{f_o}{f_{sync}}$	synchronizing ratio		1 : 2.9	1 : 3	–	

Vertical deflection circuit for monitor applications

TDA4800

TEST AND APPLICATION INFORMATION

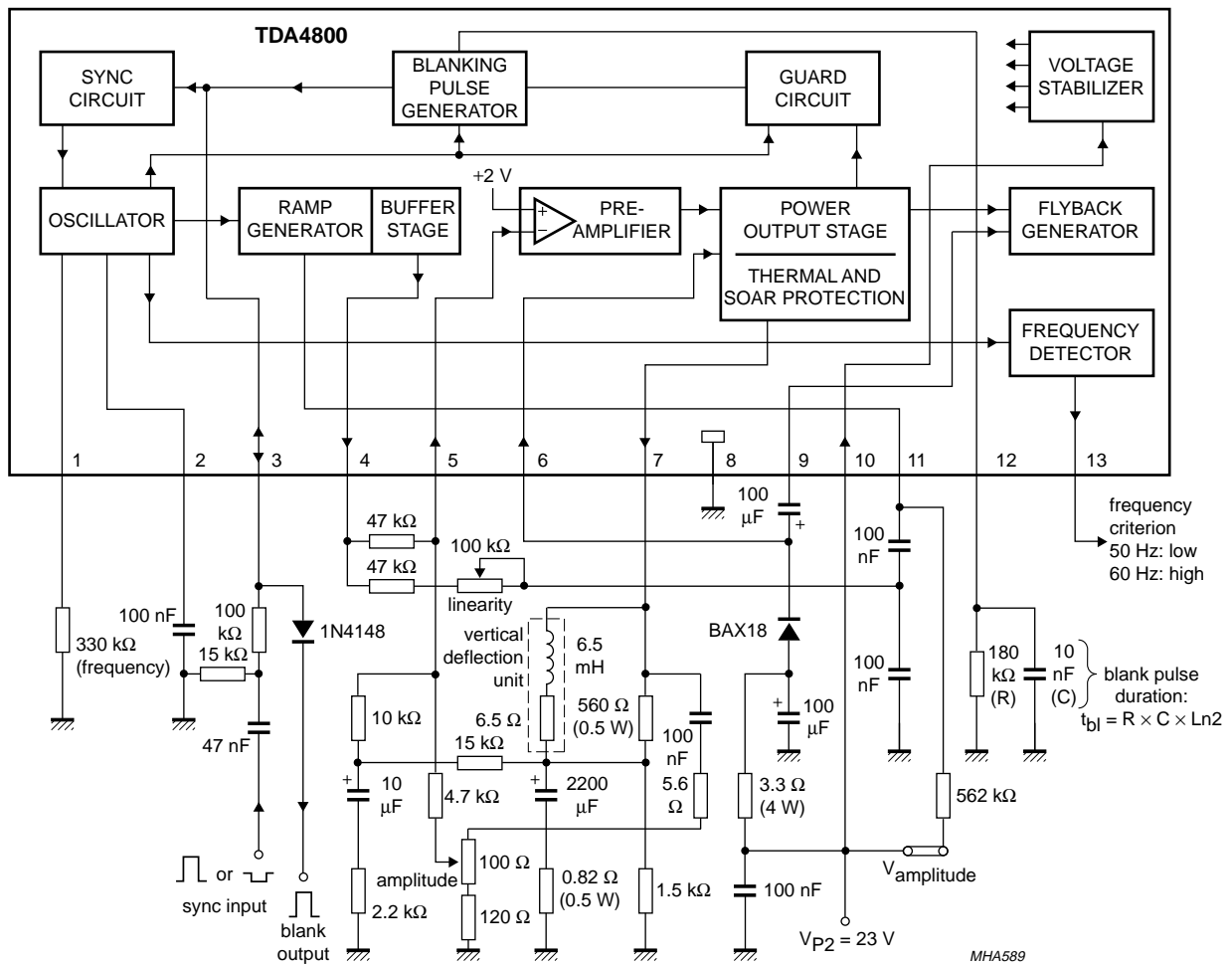

Fig.4 Test and application circuit.

Vertical deflection circuit for monitor applications

TDA4800

TDA4800 in the test and application circuit (see Fig.4)

SYMBOL	PARAMETER	CONDITIONS	TYP.	UNIT
V_{P2}	supply voltage		23	V
I_P	supply current		215	mA
V_7	DC output voltage		11.8	V
V_{7M}	peak output voltage		45	V
I_7	output current		0.8	A
$I_{Y(p-p)}$	vertical deflection current (peak-to-peak value)		1.5	A
t_{fb}	flyback time		0.3	ms
t_{bl}	blanking pulse duration		1.25	ms
P_{tot}	total power dissipation		3.3	W
f_o	free running oscillator frequency	without sync	45	Hz

Vertical deflection circuit for monitor applications

TDA4800

PACKAGE OUTLINE

DBS13P: plastic DIL-bent-SIL power package; 13 leads (lead length 12 mm)

SOT141-6

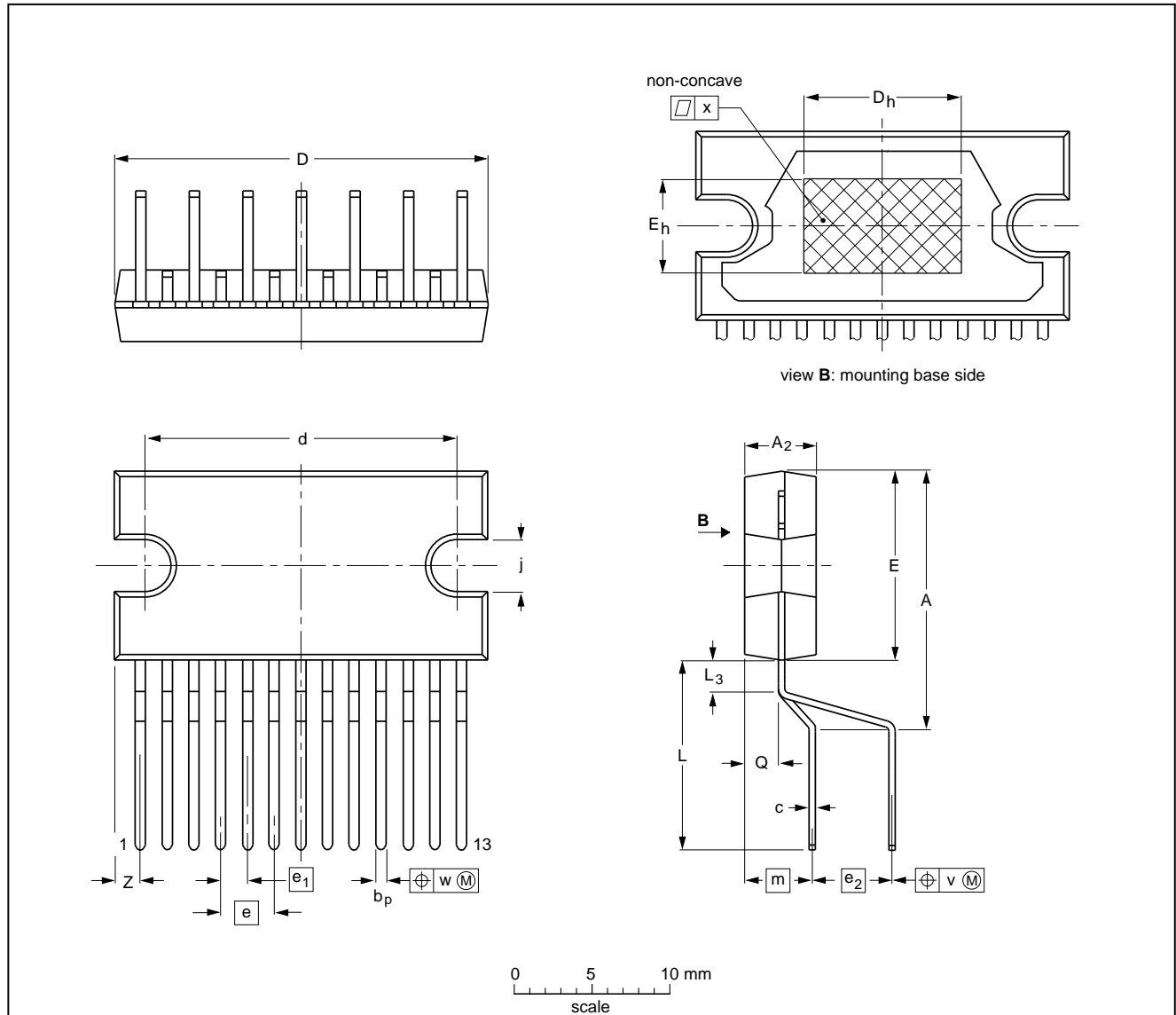

DIMENSIONS (mm are the original dimensions)

UNIT	A	A ₂	b _p	c	D ⁽¹⁾	d	D _h	E ⁽¹⁾	e	e ₁	e ₂	E _h	j	L	L ₃	m	Q	v	w	x	Z ⁽¹⁾
mm	17.0 15.5	4.6 4.2	0.75 0.60	0.48 0.38	24.0 23.6	20.0 19.6	10	12.2 11.8	3.4	1.7	5.08	6	3.4 3.1	12.4 11.0	2.4 1.6	4.3	2.1 1.8	0.8	0.25	0.03	2.00 1.45

Note

1. Plastic or metal protrusions of 0.25 mm maximum per side are not included.

OUTLINE VERSION	REFERENCES				EUROPEAN PROJECTION	ISSUE DATE
	IEC	JEDEC	EIAJ			
SOT141-6						92-11-17 95-03-11

Vertical deflection circuit for monitor applications

TDA4800

MOUNTING INSTRUCTIONS FOR 13-LEAD DBS13P POWER PACKAGE

The rise in temperature caused by power dissipation in the circuit is reduced by adding a heatsink with a sufficiently low thermal resistance:

$R_{th(mb-h)} + R_{th(h-a)} = R_{th(mb-a)}$
 (e.g. the heatsink of Fig.5). It is possible to attach the package to the heatsink by screws (Fig.6) or by a compression spring (Fig.7). A layer of silicon grease between the heatsink and the mounting base optimizes thermal contact.

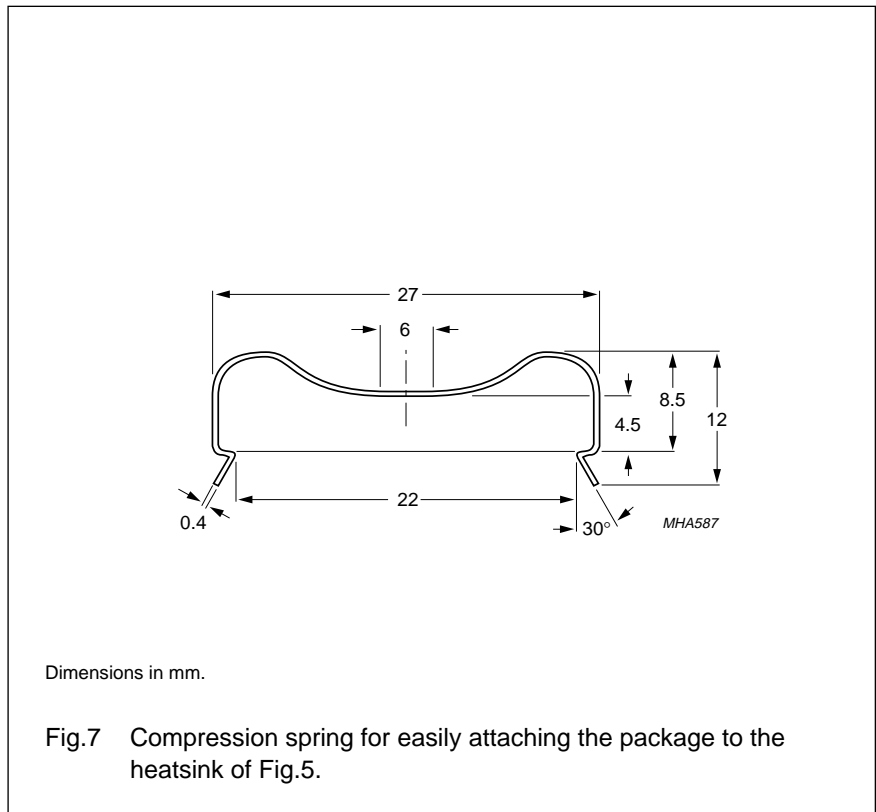
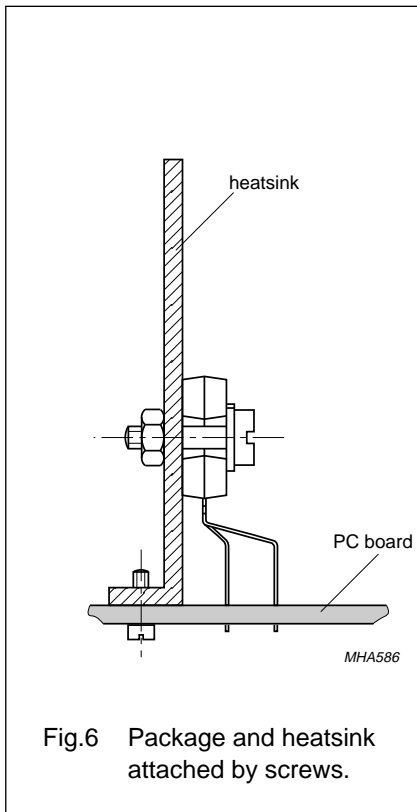
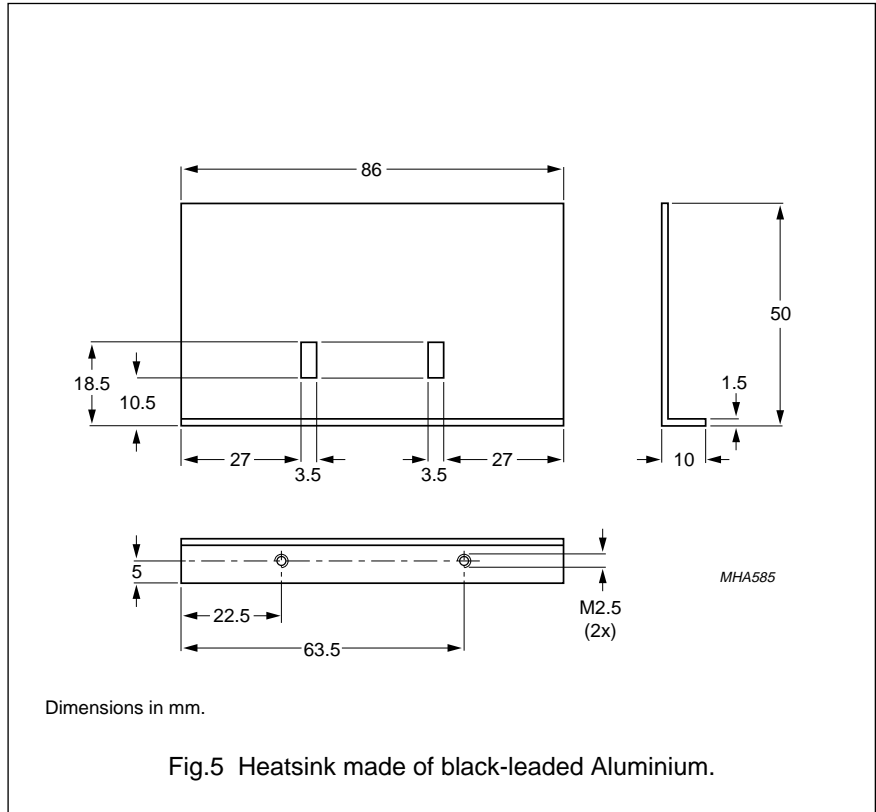

Vertical deflection circuit for monitor applications

TDA4800

SOLDERING

Introduction

There is no soldering method that is ideal for all IC packages. Wave soldering is often preferred when through-hole and surface mounted components are mixed on one printed-circuit board. However, wave soldering is not always suitable for surface mounted ICs, or for printed-circuits with high population densities. In these situations reflow soldering is often used.

This text gives a very brief insight to a complex technology. A more in-depth account of soldering ICs can be found in our "IC Package Databook" (order code 9398 652 90011).

Soldering by dipping or by wave

The maximum permissible temperature of the solder is 260 °C; solder at this temperature must not be in contact with the joint for more than 5 seconds. The total contact time of successive solder waves must not exceed 5 seconds.

The device may be mounted up to the seating plane, but the temperature of the plastic body must not exceed the specified maximum storage temperature ($T_{stg\ max}$). If the printed-circuit board has been pre-heated, forced cooling may be necessary immediately after soldering to keep the temperature within the permissible limit.

Repairing soldered joints

Apply a low voltage soldering iron (less than 24 V) to the lead(s) of the package, below the seating plane or not more than 2 mm above it. If the temperature of the soldering iron bit is less than 300 °C it may remain in contact for up to 10 seconds. If the bit temperature is between 300 and 400 °C, contact may be up to 5 seconds.

DEFINITIONS

Data sheet status	
Objective specification	This data sheet contains target or goal specifications for product development.
Preliminary specification	This data sheet contains preliminary data; supplementary data may be published later.
Product specification	This data sheet contains final product specifications.
Limiting values	
Limiting values given are in accordance with the Absolute Maximum Rating System (IEC 134). Stress above one or more of the limiting values may cause permanent damage to the device. These are stress ratings only and operation of the device at these or at any other conditions above those given in the Characteristics sections of the specification is not implied. Exposure to limiting values for extended periods may affect device reliability.	
Application information	
Where application information is given, it is advisory and does not form part of the specification.	

LIFE SUPPORT APPLICATIONS

These products are not designed for use in life support appliances, devices, or systems where malfunction of these products can reasonably be expected to result in personal injury. Philips customers using or selling these products for use in such applications do so at their own risk and agree to fully indemnify Philips for any damages resulting from such improper use or sale.

Vertical deflection circuit for monitor
applications

TDA4800

NOTES

Vertical deflection circuit for monitor
applications

TDA4800

NOTES

Philips Semiconductors – a worldwide company

Argentina: see South America

Australia: 34 Waterloo Road, NORTH RYDE, NSW 2113,
Tel. +61 2 9805 4455, Fax. +61 2 9805 4466

Austria: Computerstr. 6, A-1101 WIEN, P.O. Box 213,
Tel. +43 1 60 101, Fax. +43 1 60 101 1210

Belarus: Hotel Minsk Business Center, Bld. 3, r. 1211, Volodarski Str. 6,
220050 MINSK, Tel. +375 172 200 733, Fax. +375 172 200 773

Belgium: see The Netherlands

Brazil: see South America

Bulgaria: Philips Bulgaria Ltd., Energoproject, 15th floor,
51 James Bourchier Blvd., 1407 SOFIA,
Tel. +359 2 689 211, Fax. +359 2 689 102

Canada: PHILIPS SEMICONDUCTORS/COMPONENTS,
Tel. +1 800 234 7381

China/Hong Kong: 501 Hong Kong Industrial Technology Centre,
72 Tat Chee Avenue, Kowloon Tong, HONG KONG,
Tel. +852 2319 7888, Fax. +852 2319 7700

Colombia: see South America

Czech Republic: see Austria

Denmark: Prags Boulevard 80, PB 1919, DK-2300 COPENHAGEN S,
Tel. +45 32 88 2636, Fax. +45 31 57 1949

Finland: Sinikalliontie 3, FIN-02630 ESPOO,
Tel. +358 9 615800, Fax. +358 9 61580/xxx

France: 4 Rue du Port-aux-Vins, BP317, 92156 SURESNES Cedex,
Tel. +33 1 40 99 6161, Fax. +33 1 40 99 6427

Germany: Hammerbrookstraße 69, D-20097 HAMBURG,
Tel. +49 40 23 53 60, Fax. +49 40 23 536 300

Greece: No. 15, 25th March Street, GR 17778 TAVROS/ATHENS,
Tel. +30 1 4894 339/239, Fax. +30 1 4814 240

Hungary: see Austria

India: Philips INDIA Ltd, Shivsagar Estate, A Block, Dr. Annie Besant Rd.
Worli, MUMBAI 400 018, Tel. +91 22 4938 541, Fax. +91 22 4938 722

Indonesia: see Singapore

Ireland: Newstead, Clonskeagh, DUBLIN 14,
Tel. +353 1 7640 000, Fax. +353 1 7640 200

Israel: RAPAC Electronics, 7 Kehilat Saloniki St, TEL AVIV 61180,
Tel. +972 3 645 0444, Fax. +972 3 649 1007

Italy: PHILIPS SEMICONDUCTORS, Piazza IV Novembre 3,
20124 MILANO, Tel. +39 2 6752 2531, Fax. +39 2 6752 2557

Japan: Philips Bldg 13-37, Kohnan 2-chome, Minato-ku, TOKYO 108,
Tel. +81 3 3740 5130, Fax. +81 3 3740 5077

Korea: Philips House, 260-199 Itaewon-dong, Yongsan-ku, SEOUL,
Tel. +82 2 709 1412, Fax. +82 2 709 1415

Malaysia: No. 76 Jalan Universiti, 46200 PETALING JAYA, SELANGOR,
Tel. +60 3 750 5214, Fax. +60 3 757 4880

Mexico: 5900 Gateway East, Suite 200, EL PASO, TEXAS 79905,
Tel. +9-5 800 234 7381

Middle East: see Italy

Netherlands: Postbus 90050, 5600 PB EINDHOVEN, Bldg. VB,
Tel. +31 40 27 82785, Fax. +31 40 27 88399

New Zealand: 2 Wagener Place, C.P.O. Box 1041, AUCKLAND,
Tel. +64 9 849 4160, Fax. +64 9 849 7811

Norway: Box 1, Manglerud 0612, OSLO,
Tel. +47 22 74 8000, Fax. +47 22 74 8341

Philippines: Philips Semiconductors Philippines Inc.,
106 Valero St. Salcedo Village, P.O. Box 2108 MCC, MAKATI,
Metro MANILA, Tel. +63 2 816 6380, Fax. +63 2 817 3474

Poland: Ul. Lukiska 10, PL 04-123 WARSZAWA,
Tel. +48 22 612 2831, Fax. +48 22 612 2327

Portugal: see Spain

Romania: see Italy

Russia: Philips Russia, Ul. Usatcheva 35A, 119048 MOSCOW,
Tel. +7 095 755 6918, Fax. +7 095 755 6919

Singapore: Lorong 1, Toa Payoh, SINGAPORE 1231,
Tel. +65 350 2538, Fax. +65 251 6500

Slovakia: see Austria

Slovenia: see Italy

South Africa: S.A. PHILIPS Pty Ltd., 195-215 Main Road Martindale,
2092 JOHANNESBURG, P.O. Box 7430 Johannesburg 2000,
Tel. +27 11 470 5911, Fax. +27 11 470 5494

South America: Rua do Rocio 220, 5th floor, Suite 51,
04552-903 São Paulo, SÃO PAULO - SP, Brazil,
Tel. +55 11 821 2333, Fax. +55 11 829 1849

Spain: Balmes 22, 08007 BARCELONA,
Tel. +34 3 301 6312, Fax. +34 3 301 4107

Sweden: Kottbygatan 7, Akalla, S-16485 STOCKHOLM,
Tel. +46 8 632 2000, Fax. +46 8 632 2745

Switzerland: Allmendstrasse 140, CH-8027 ZÜRICH,
Tel. +41 1 488 2686, Fax. +41 1 481 7730

Taiwan: Philips Semiconductors, 6F, No. 96, Chien Kuo N. Rd., Sec. 1,
TAIPEI, Taiwan Tel. +886 2 2134 2870, Fax. +886 2 2134 2874

Thailand: PHILIPS ELECTRONICS (THAILAND) Ltd.,
209/2 Sanpavuth-Bangna Road Prakanong, BANGKOK 10260,
Tel. +66 2 745 4090, Fax. +66 2 398 0793

Turkey: Talatpasa Cad. No. 5, 80640 GÜLTEPE/ISTANBUL,
Tel. +90 212 279 2770, Fax. +90 212 282 6707

Ukraine: PHILIPS UKRAINE, 4 Patrice Lumumba str., Building B, Floor 7,
252042 KIEV, Tel. +380 44 264 2776, Fax. +380 44 268 0461

United Kingdom: Philips Semiconductors Ltd., 276 Bath Road, Hayes,
MIDDLESEX UB3 5BX, Tel. +44 181 730 5000, Fax. +44 181 754 8421

United States: 811 East Arques Avenue, SUNNYVALE, CA 94088-3409,
Tel. +1 800 234 7381

Uruguay: see South America

Vietnam: see Singapore

Yugoslavia: PHILIPS, Trg N. Pasica 5/v, 11000 BEOGRAD,
Tel. +381 11 625 344, Fax. +381 11 635 777

For all other countries apply to: Philips Semiconductors, Marketing & Sales Communications,
Building BE-p, P.O. Box 218, 5600 MD EINDHOVEN, The Netherlands, Fax. +31 40 27 24825

Internet: <http://www.semiconductors.philips.com>

© Philips Electronics N.V. 1997

SCA53

All rights are reserved. Reproduction in whole or in part is prohibited without the prior written consent of the copyright owner.

The information presented in this document does not form part of any quotation or contract, is believed to be accurate and reliable and may be changed without notice. No liability will be accepted by the publisher for any consequence of its use. Publication thereof does not convey nor imply any license under patent- or other industrial or intellectual property rights.

Printed in The Netherlands

547047/1200/02/pp16

Date of release: 1997 Mar 27

Document order number: 9397 750 01396

Let's make things better.

**Philips
Semiconductors**



PHILIPS